

1 x

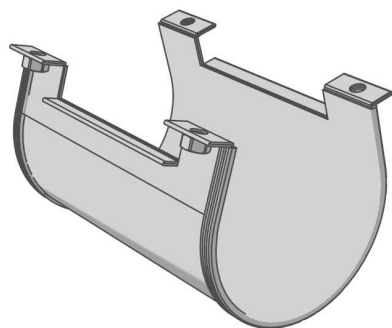

4 x

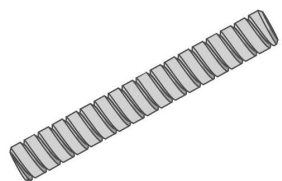

4 x



4 x

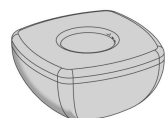

1

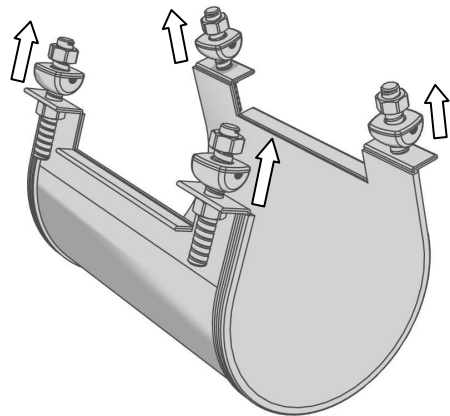

2

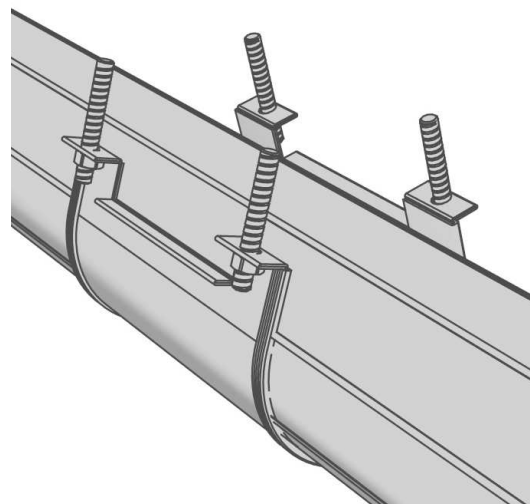

3

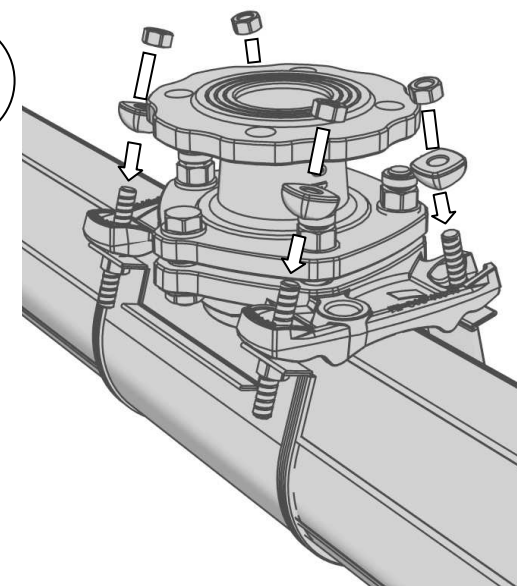

4

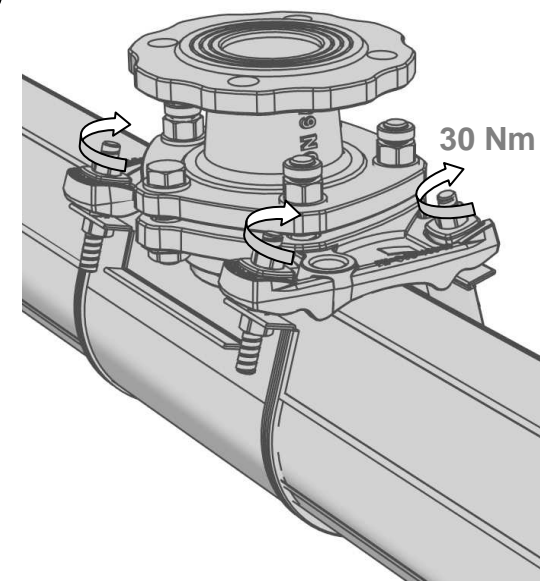

OPTIM 